

ORIENTATION

NOZZLE SCHEDULE					
MARK	SIZE	WALL THK.	NOZ. TYPE	RTG-PSI	FUNCTION
A	5"	.258"	RF-SO	150	INLET
B	5"	.258"	RF-SO	150	OUTLET
C	2"	--	FULL CPLG	3000	DRAIN
D	1/2"	--	HALF CPLG	6000	VENT

NOTES:

- FLANGE BOLT HOLES TO STRADDLE VESSEL Q'S.
- APPROX. WEIGHT:
 - DRY-175 lbs.
 - FLOODED(WATER)-260 lbs.
- UNIT IS PAINTED WITH A HIGH HEAT RESISTANT PAINT, SAFETY BLUE.

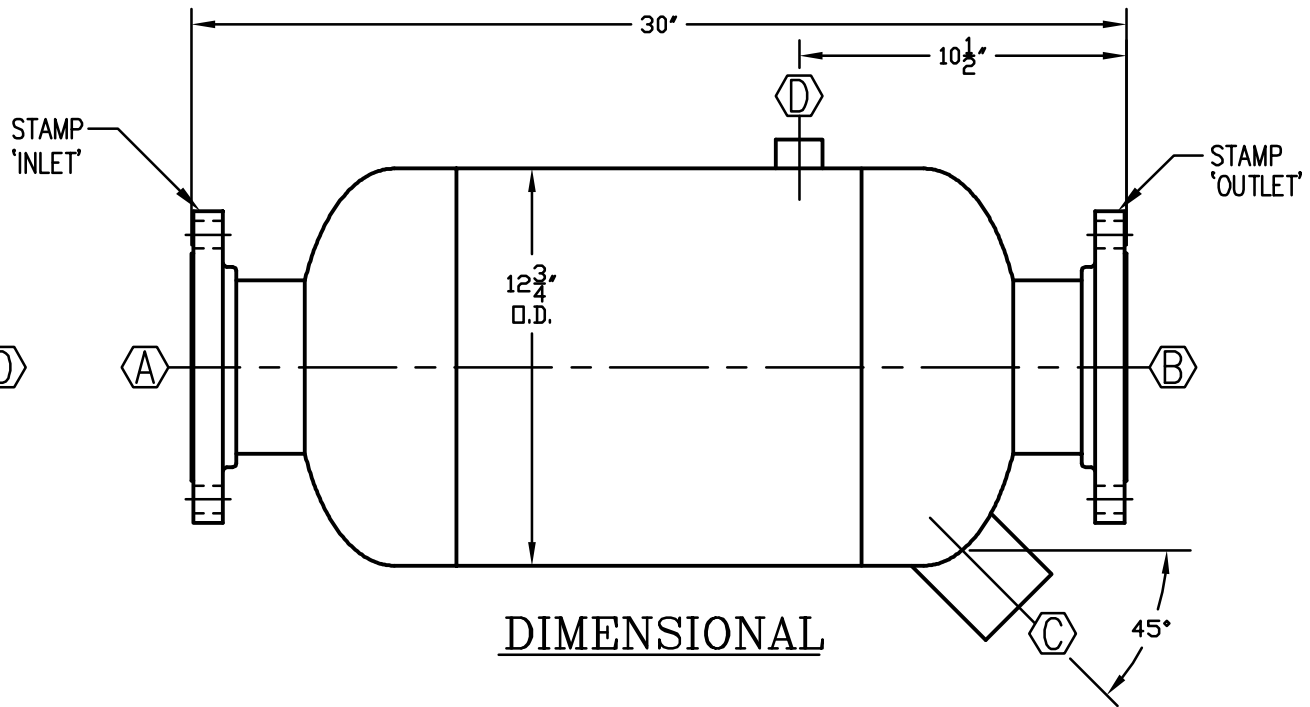

DIMENSIONAL

CONSTRUCTION	
A.S.M.E. SECTION VIII DIVISION I	
A.S.M.E. U-1 STAMP REQUIRED	
DESIGN SPECIFICATIONS	
DES. PRESS.	150 PSIG
DES. TEMP.	500° F.
FULL VACUUM	YES
CORR. ALL.	1/16"
HYDRO. TEST	195 PSIG
STRESS REL.	NONE REQ'D
RADIOGRAPH	NONE REQ'D
M.D.M.T	-20° F. @ 150 PSIG

REVISION: 0					
NO.	DESCRIPTION	BY DATE	NO.	DESCRIPTION	BY DATE
DIDION SEPARATOR COMPANY A DIVISION OF  DIDION'S MECHANICAL <i>NOT BIGGEST....BEST!</i>					
PH: (419) 483-2226		FX: (419) 483-4382		WEB: didionseparator.com	
				e-mail: dmech@didionsmech.com	
DESCRIPTION: HORIZONTAL/DOWN FLOW SEPARATOR					
MODEL #DSL-5-150					
DRWN. JLD	DATE: 03/22/10	APPR.	DATE:		
CHK.	DATE:	APPR.	DATE:		
SCALE:	DRAWING NUMBER			REV.	SHEET
D.M. NO.	DSL-5-150-SALES			0	NO. 1
P.O. NO.					OF 1