

ORIENTATION

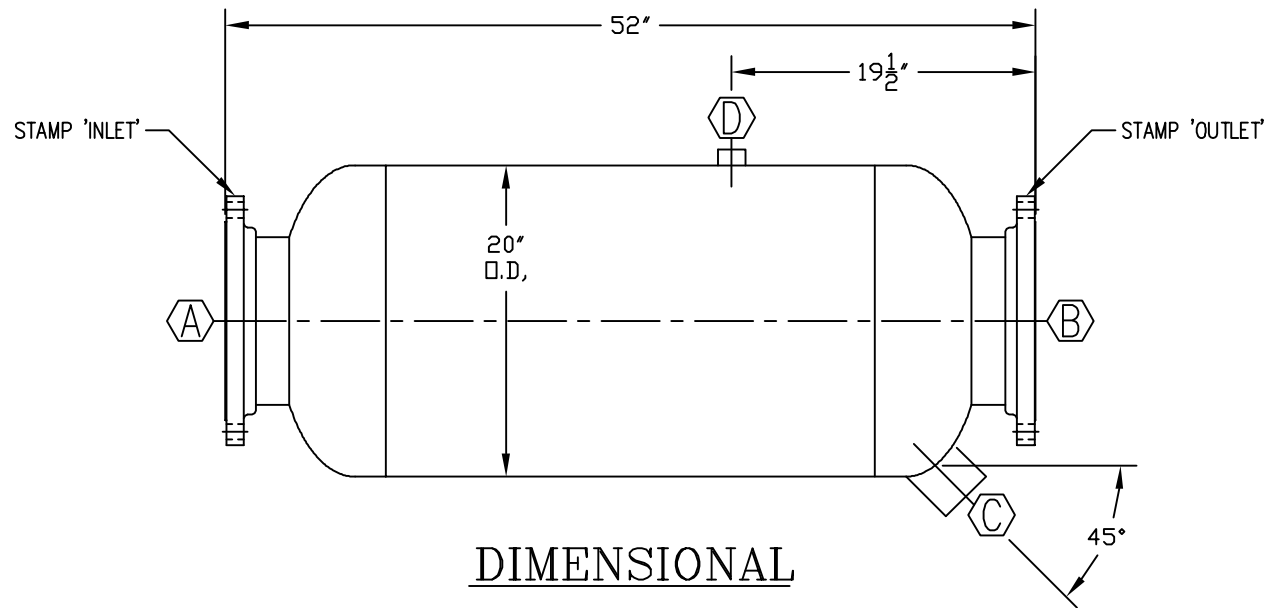

DIMENSIONAL

NOZZLE SCHEDULE					
MARK	SIZE	WALL THK.	NOZ. TYPE	RTG-PSI	FUNCTION
A	10"	.365"	RF-SO	150	INLET
B	10"	.365"	RF-SO	150	OUTLET
C	2 1/2"	--	FULL CPLG	3000	DRAIN
D	3/4"	--	HALF CPLG	6000	VENT

- NOTES:
1. FLANGE BOLT HOLES TO STRADDLE VESSEL Q'S.
 2. APPROX. WEIGHT:
 - a. DRY-604 lbs.
 - b. FLOODED(WATER)-982 lbs.
 3. UNIT IS PAINTED WITH A HIGH HEAT RESISTANT PAINT, SAFETY BLUE.

<u>CONSTRUCTION</u>	
A.S.M.E. SECTION VIII DIVISION I 2013 EDITION	
A.S.M.E. -U1 STAMP REQUIRED	
<u>DESIGN SPECIFICATIONS</u>	
DES. PRESS.	150 PSIG
DES. TEMP.	500° F.
FULL VACUUM	YES
CORR. ALL.	1/16"
HYDRO. TEST	195 PSIG
STRESS REL.	NONE REQ'D
RADIOGRAPH	NONE REQ'D
M.D.M.T	-20° F. @ 150 PSIG

REVISION: 0					
NO.	DESCRIPTION	BY DATE	NO.	DESCRIPTION	BY DATE

DIDION SEPARATOR COMPANY
A DIVISION OF



DIDION'S MECHANICAL
NOT BIGGEST....BEST!

PH: (419) 483-2226 WEB: didionseparator.com
 FX: (419) 483-4382 e-mail: dmech@didionsmech.com

DESCRIPTION: HORIZONTAL/DOWN SEPARATOR
 MODEL #DSL-10-150

DRWN. JLD	DATE: 03/23/10	APPR.	DATE:
CHK.	DATE:	APPR.	DATE:
SCALE:	DRAWING NUMBER		REV.
D.M. NO.	DSL-10-150-SALES		0
P.O. NO.			SHEET NO. 1 OF 1